

# AirHEAD 5

## Benchtop Pneumatic Box Frame Press

### FEATURES

- Box frame construction for superior rigidity.
- No electrical power required, only compressed shop air.
- This press is equipped with a powerful multi stage pneumatic cylinder with 4 tons capacity.
- The unit has a space saving foot print of 10 x 18", suited for bench top applications.
- A top of a line FRL is to protect and to ensure long service life of the cylinder.
- The press is ideal for fast spaced production, using velocity of up to 120 inches per second.
- Custom tooling can be easily mounted to the cylinder's RAM through 3 easily accessible bolt holes.
- The lower mounting plate has 8 threaded holes and 3 dowel holes.
- 4 ton pneumatic press is equipped with a foot valve. As an option two push buttons and the necessary valves maybe added if required.

**\$4975\***

\*Plus actual handling / shipping cost and applicable taxes for BC. Funds are in Canadian Dollars.

### SPECIFICATIONS

- **Capacity:** 3.8 tons @100 psi
- **Bore:** 5" / **Stroke:** 1"
- **No. of Stages:** 4
- **Speed:** Up to 120 inches/second
- **Air Intake:** Compressed air, up to 125 psi
- **Air Connection:** Standard 1/2" quick connect
- **Work Space (inside):** W14" x D3.1" (or D5.6") x H8.3"
- **Outer Dimensions:** W18" x D10" x H 31.25"
- **Weight:** 150 lbs

### APPLICATION IDEAS

- Blanking
- Piercing
- Lancing
- Shearing or cut off
- Bending
- Trimming
- Shaving
- Compound
- Fine blanking
- Coining
- Embossing
- Forming
- Crimping
- Extruding
- Bulging
- Swaging
- Drawing
- Riveting
- Die cutting
- Assembling

**Vor**TOOL  
MANUFACTURING

Vortool Manufacturing Ltd.  
Unit 240 19358-96 Ave.  
Surrey, BC V4N 4C1  
Canada

**Call:** 604.262.1966  
**Call Tool Free:** 888.450.0632  
info@vortool.com  
vortool.com

# AirHEAD 5

Benchtop Pneumatic Box Frame Press

## DIMENSIONS

Mounting holes dimension, locations supplied with every unit.

Custom manufactured stamping tools are available to fit the press and your needs.

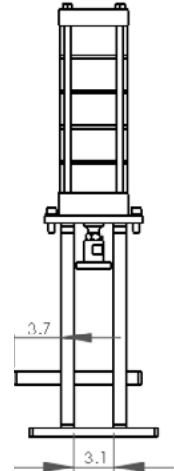
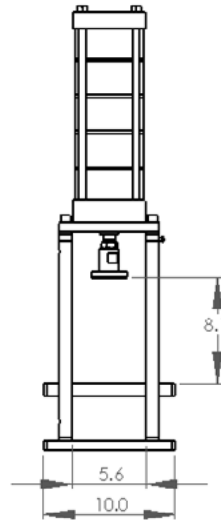
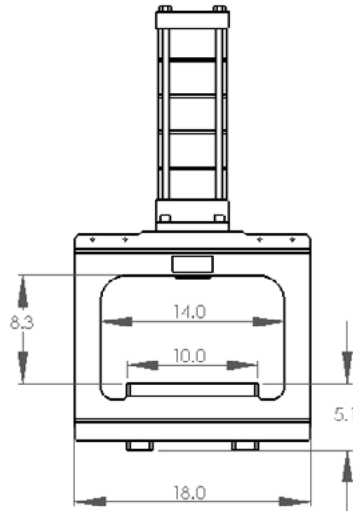

## OTHER AIRHEAD BENCHTOP PNEUMATIC BOX FRAME PRESS OPTIONS

- **Capacity:** 1 - 5 tons (5" bore) depends of the number of stages. Available for up to 10 tons - Stroke: 0.5" x 12".
- **Bore and No. of stages:** 5" standard. Available between 1.5" - 8" using up to 5 stages per cylinder. The capacity is between 300 - 20,000 lbs (0.15 - 10 tons). Adapter plate required.
- 4 ton pneumatic press is equipped with a foot valve. As an option two push buttons and the necessary valves maybe added if required.
- **Work space:** For your custom built press, specify the inside dimensions W x D x H.
- **Dedicated table frames are available.** Choose between two steel tube welded models or one that is made of 80/20 aluminum structure. All three models may be floor mounted or equipped with casters. Custom frames are also available.
- The press is **fully customizable**, based on your specific requirement.
- Get custom tooling for this press for all stamping applications.

*It works under pressure!*

Configure and order your custom Airhead Benchtop Pneumatic Box Frame Press today.

We deliver in 4 weeks.

Ask for a quote.

**Vor**TOOL  
MANUFACTURING

**Vortool Manufacturing Ltd.**

Unit 240 19358-96 Ave.  
Surrey, BC V4N 4C1  
Canada

**Call:** 604.262.1966

**Call Tool Free:** 888.450.0632

info@vortool.com  
vortool.com